

Dòng sản phẩm khớp nối cao su



Dòng AMS



Dòng AMS II



Dòng AMT



Dòng AMU



KIỂU 1000



Dòng AMT

Kết nối hình cầu đôi với mặt bích nối

- Mặt bích: SS41 (có thể thay đổi)
- Dây: Sợi thép cacbon
- Chất đàn hồi: Cao su tổng hợp đặc biệt
- Vải gia cố: Sợi tổng hợp

Cấu trúc & Vật liệu

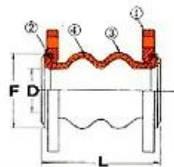

SYMBOL	PART	ENGINEERING MATERIAL
1	FLANGES	SS41 (CHANGEABLE)
2	WIRE	CARBON STEEL WIRES STRAND
3	ELASTOMER	SPECIAL SYNTHETIC RUBBER
4	REINFORCING FABRIC	SYNTHETIC FIBER

Các chuyển động được phép

1. Nén trục

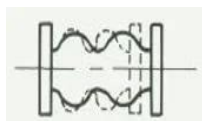

2. Độ giãn dài trục

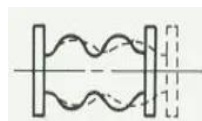

3. Chuyển động ngang

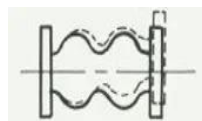

4. Độ lệch góc

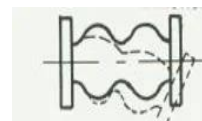

Điều kiện hoạt động

Operating Pressure	16 kg/cm ²	8 kg/cm ²	25 kg/cm ²	16 kg/cm ²
Burst Pressure	60 kg/cm ²	24 kg/cm ²	75 kg/cm ²	48 kg/cm ²
Vacuum Rating	650 mm/Hg		650 mm/Hg	
Temperature				

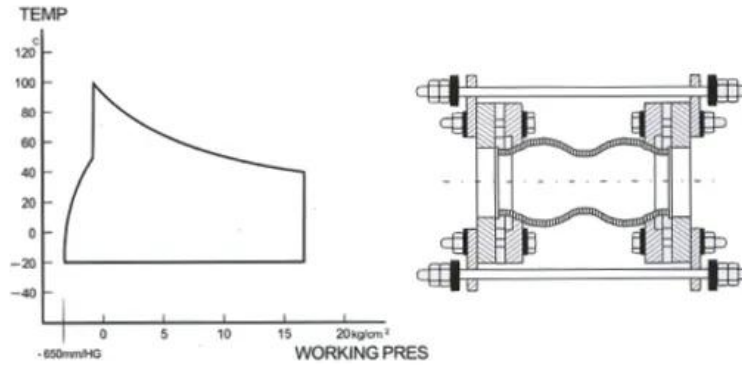

AMT WITH ROOT RING

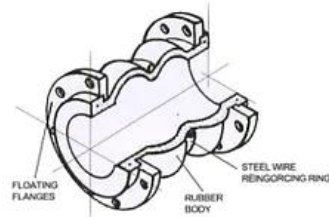

Root ring must be installed when pressure (Test Surge, Operating) exceeds the rating below:			
150 PSIG	1-1/4" (32mm)	THRU	4" (100mm)
135 PSIG	5" (125mm)	THRU	10" (250mm)
90 PSIG	12" (300mm)	THRU	14" (350mm)
45 PSIG	16" (400mm)	THRU	24" (600mm)

Kích thước

AMT-102	2"	175	52	86	50	30	45	35°
AMT-102H	2-1/2"	175	68	106	50	30	45	35°
AMT-103	3"	175	76	116	50	30	45	35°
AMT-104	4"	225	103	150	50	35	40	35°
AMT-105	5"	225	128	180	50	35	40	35°
AMT-106	6"	225	152	209	50	35	40	35°
AMT-108	8"	325	194	260	60	35	35	30°
AMT-110	10"	325	250	320	60	35	35	30°
AMT-112	12"	325	300	367	60	35	35	30°
AMT-114	14"	350	320	408	40	30	30	20°
AMT-116	16"	350	372	472	40	30	30	20°
AMT-118	18"	350	415	522	40	30	30	20°
AMT-120	20"	350	454	570	40	30	30	20°
AMT-124	24"	350	580	690	40	30	30	20°

Item	Size (in)	L	DØ	FØ	Allowable Movements			
					Axial		Trans Move	Angular Deflection
					Comp	Elong		
AMT-201H	1-1/2"	7"	40	69	50mm	30mm	45mm	35°
AMT-201	2"	7"	52	86	50	30	45	35°
AMT-202H	2-1/2"	7"	68	106	50	30	45	35°
AMT-203	3"	7"	76	116	50	35	45	35°
AMT-204	4"	9"	103	150	50	35	40	35°
AMT-205	5"	9"	128	180	50	35	40	30°
AMT-206	6"	9"	152	209	50	35	40	30°
AMT-208	8"	13"	194	260	60	35	35	30°
AMT-210	10"	13"	250	320	60	35	35	30°
AMT-212	12"	13"	300	367	60	35	35	20°